

DETAIL C

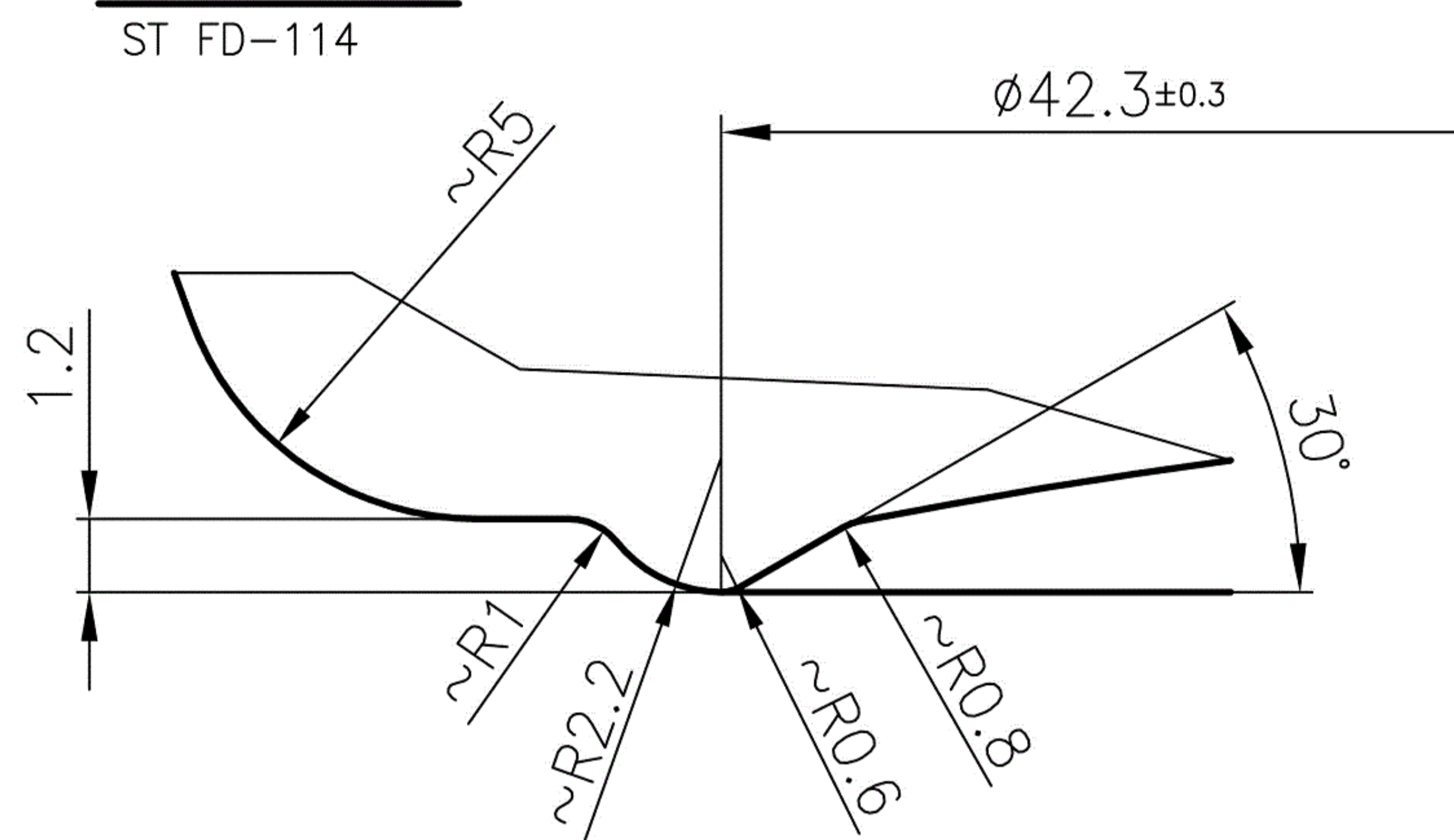

DESIGN OF THE OPPOSITE SIDE OF BOTTLE

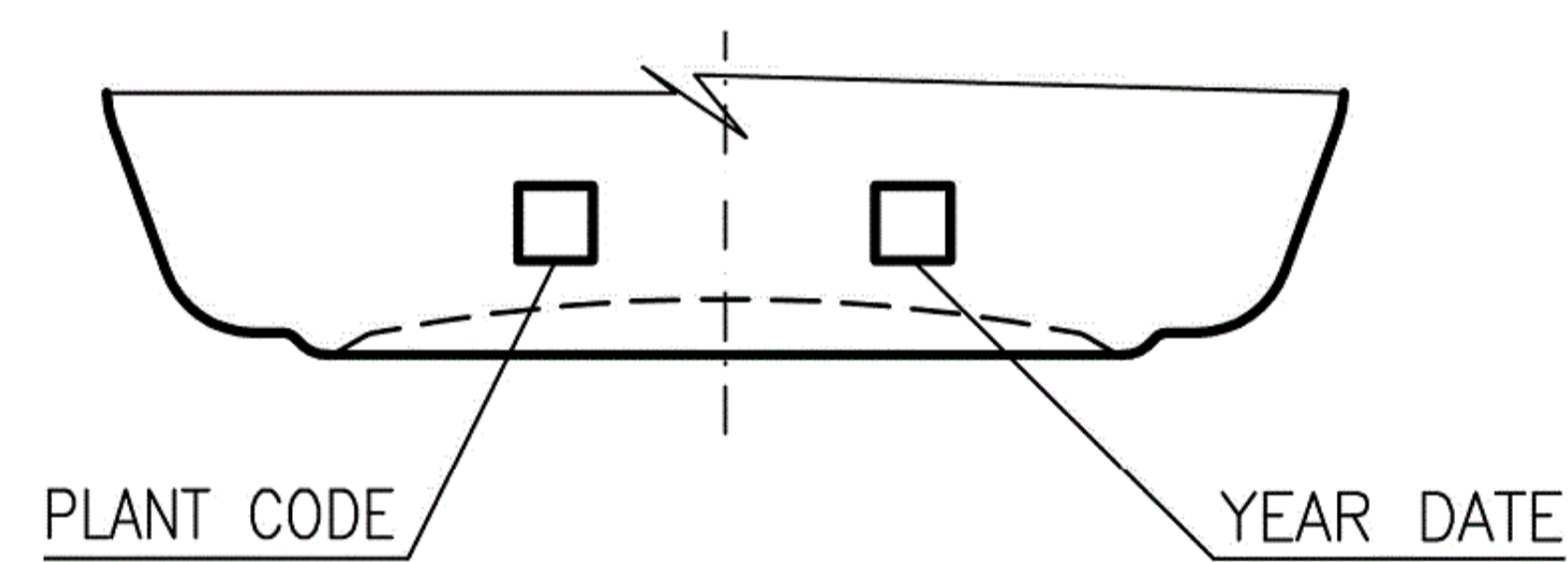

DETAIL A

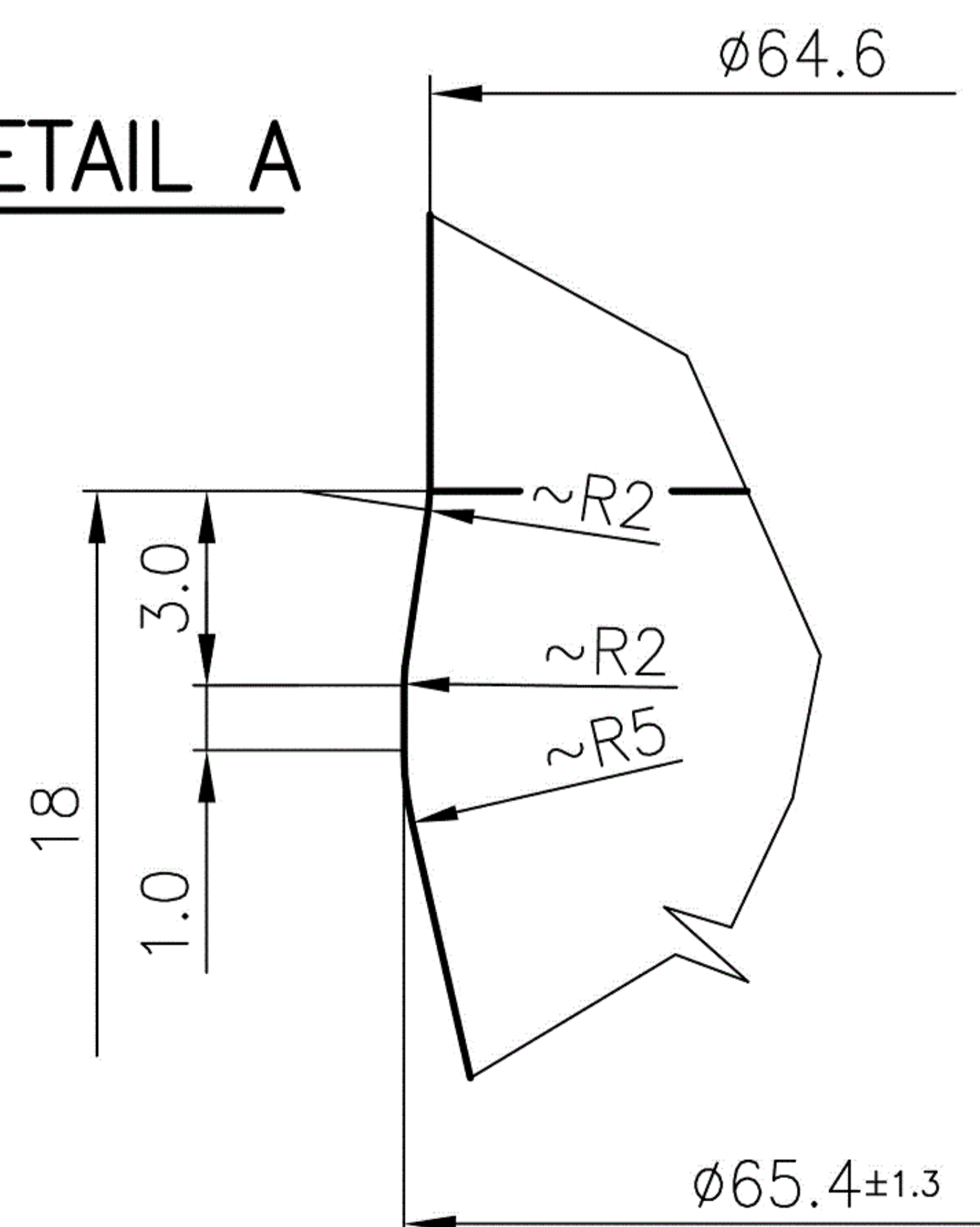

DETAIL B

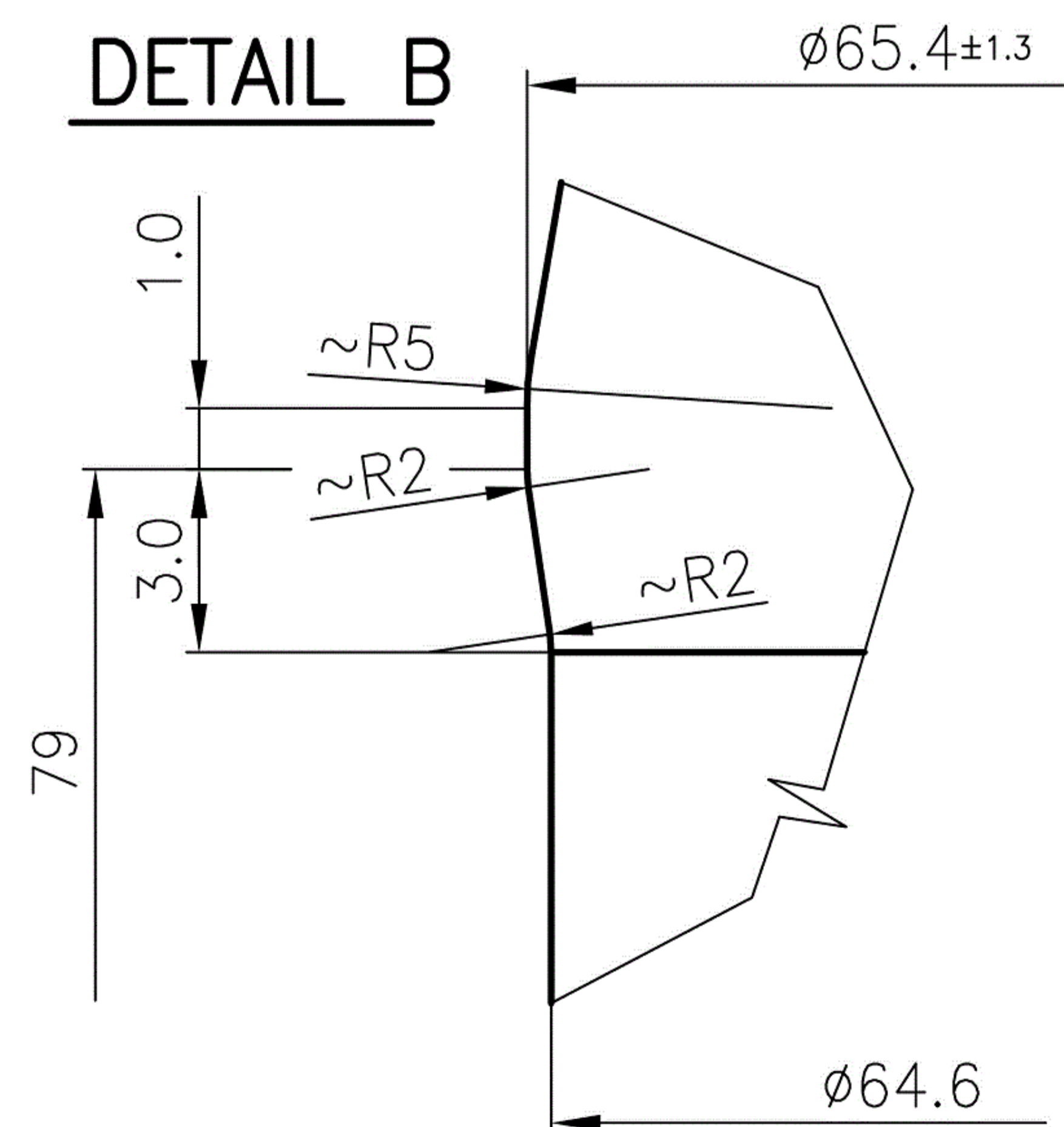

BOTTOM DESIGN

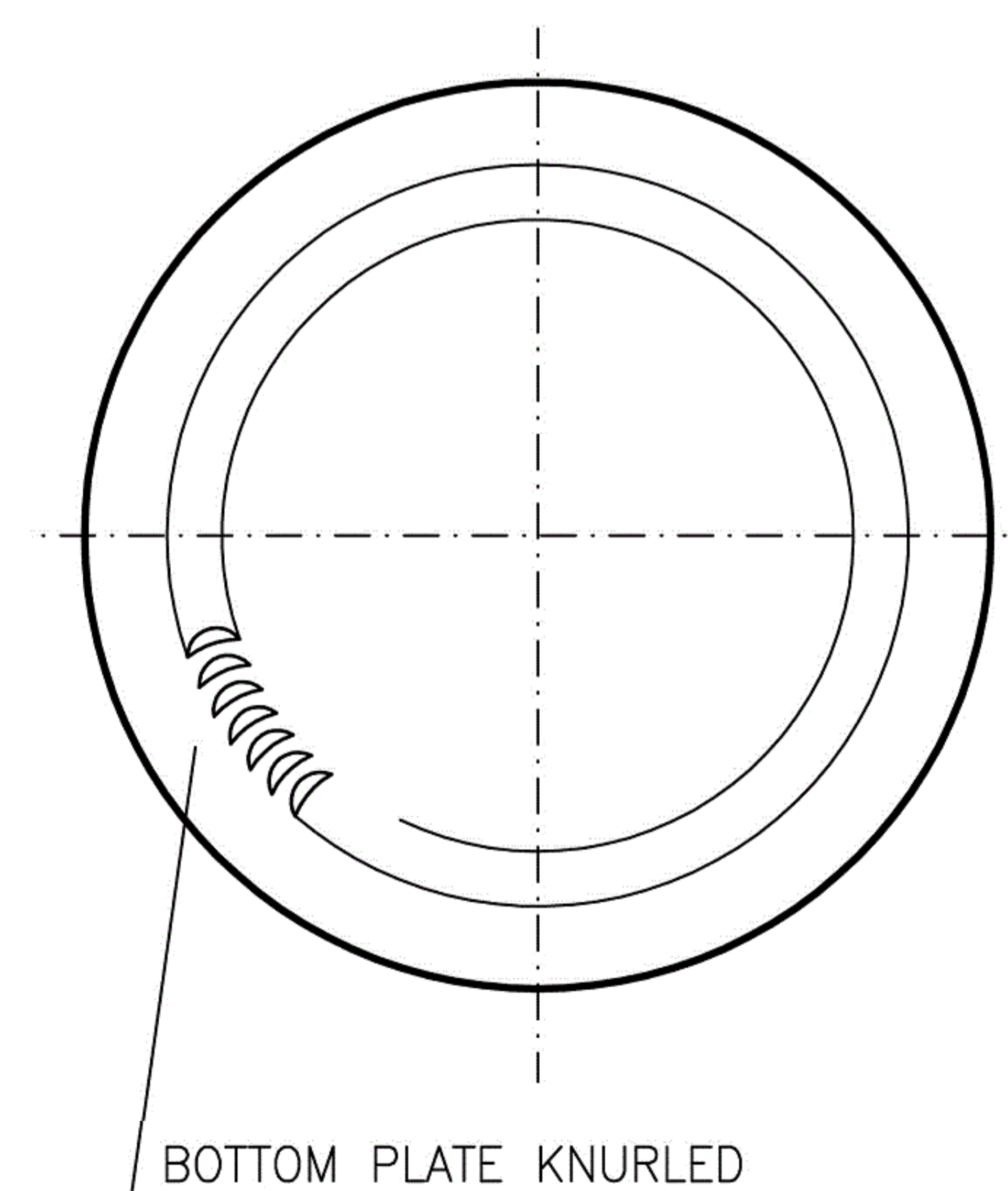

Bezeichnung / Description

250ml Boneco-Glas T058

Randvollvolumen Brimful capacity	275 ml
Nennvolumen Useful capacity	250 ml
Volumentoleranz (einzel) Tolerance volume (single)	± 7 ml
Mündung Finish	TO 58
Farbe Color	weiß / flint
Gewicht Weight	ca. 140 g
Thermoschock Thermal shock	max. ΔT 45°
max. Innendruck max. Internal pressure	ohne / without CO ₂



HILLEBRANDT GLAS

Tietjenstraße 9
12309 Berlin
Germany

- +49 (0)30 746 56 26
- +49 (0)30 745 03 72
- kontakt@hillebrandt-glas.de
- www.hillebrandt-glas.de